

Installation Guide

Shut-off valve

Type QDV 15

148R9540

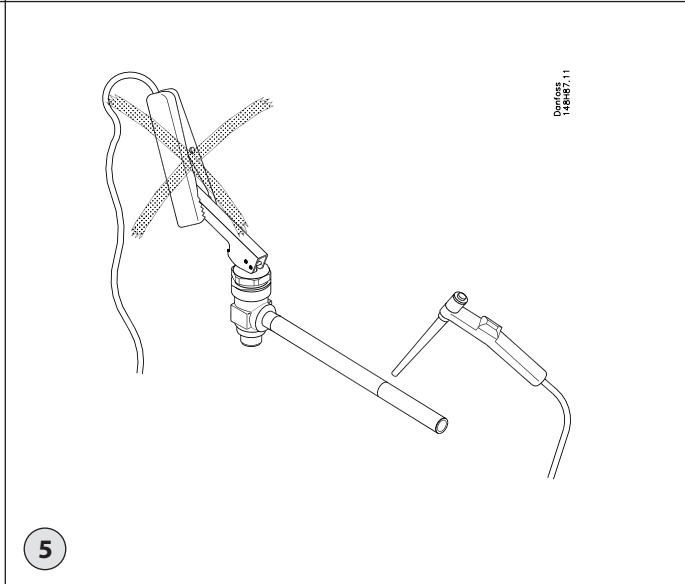
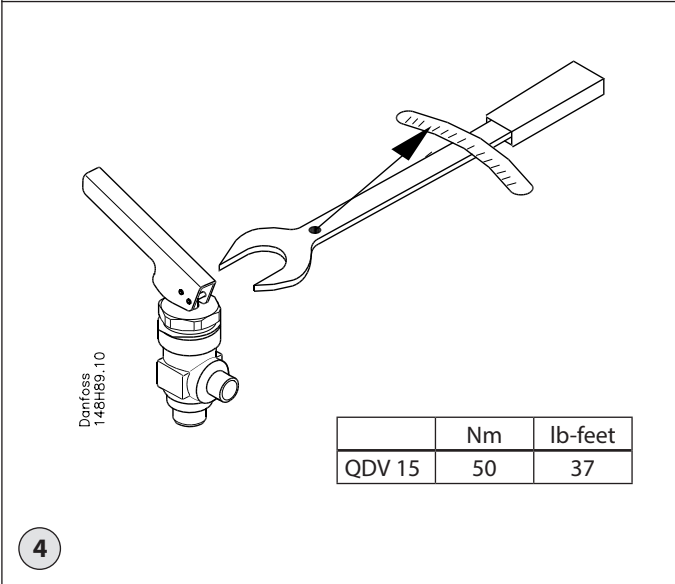
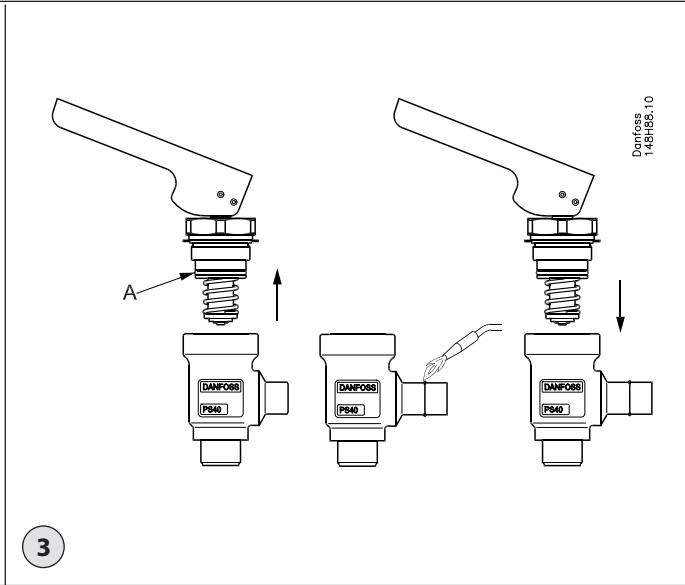
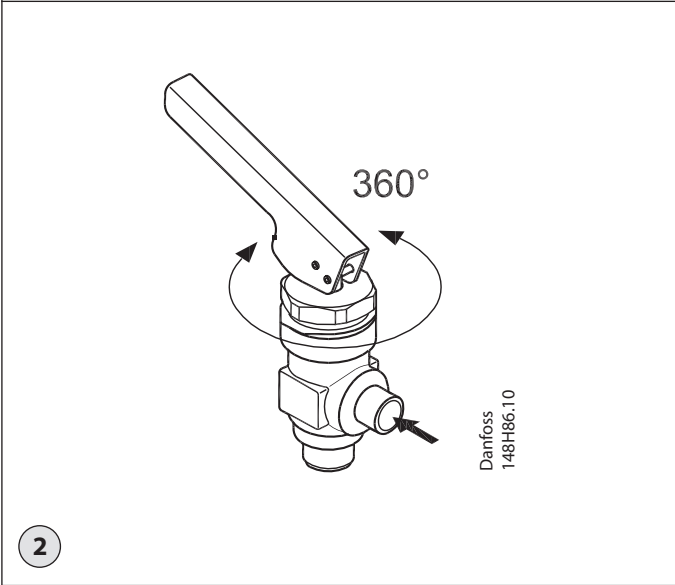
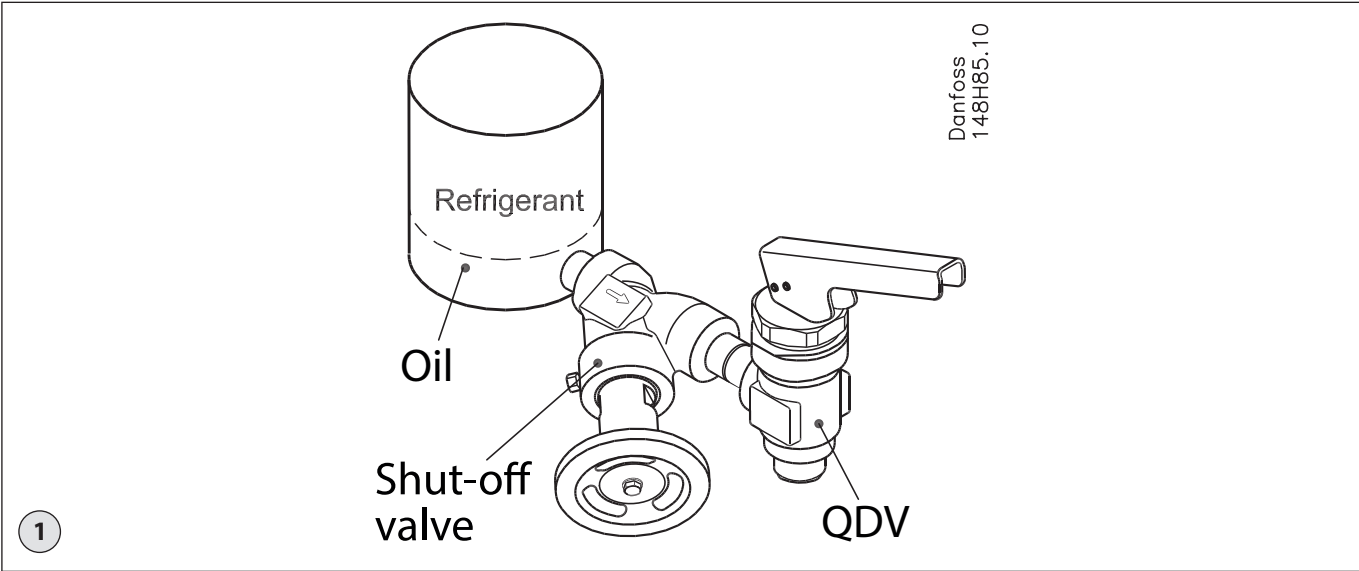

ENGLISH

Refrigerants:

Applicable to R717 (Ammonia).

Flammable hydrocarbons are not recommended. QDV is a backpressure dependent valve. The valve is only recommended for use in open circuits. For further information please contact Danfoss.

Temperature range:

QDV 15: $-50/+150^{\circ}\text{C}$ ($-58/+302^{\circ}\text{F}$)

Pressure range:

The valves are designed for a max. working pressure of 40 bar g (580 psi g). In order to prevent hydraulic pressure building up between the stop valve and the QDV an integral relief device is included opening the valve slowly if the pressure exceeds 16 bar (232 psig).

Installation:

The valve must be installed after a stop valve with the spindle vertically upwards and with flow direction from the side branch (fig. 1).



If any tube or hose is mounted on the outlet of the QDV it has to be calculated to prevent backpressure building up when relieving. Blocking the outlet of the QDV will cause danger (hydraulic pressure building up).

An outlet hose of the same size as the outlet connection of the QDV valve must be used.

The handle can be turned 360° for optimizing operation position (fig. 2). Valves should only be operated by hand without the use of tools or other devices. The valve is designed to withstand a high internal pressure. However, the piping system should be designed to avoid liquid traps and reduce the risk of hydraulic pressure caused by thermal expansion. It must be ensured that the valve is protected from pressure transients like "liquid hammer" in the system.

Recommended flow direction:

The valve must be installed with flow direction from the side branch (fig. 2).

Welding:

The bonnet should be removed before welding (fig. 4) to prevent damage to the O-ring between the valve body and bonnet, as well as the Teflon cone ring in the valve seat.

Only materials and welding methods, compatible with the valve housing material, must be welded to the valve housing.

The valve should be cleaned internally to remove welding debris on completion of welding and before the valve is reassembled.

Avoid welding debris and dirt in the threads of the housing and the bonnet. Removing the bonnet can be omitted provided that:

The temperature in the area between the valve body and bonnet during welding does not exceed $+150^{\circ}\text{C}/+302^{\circ}\text{F}$.

This temperature depends on the welding method as well as on any cooling of the valve body during the welding itself.

(Cooling can be ensured by, for example, wrapping a wet cloth around the valve body.) Make sure that no dirt, welding debris etc. get into the valve during the welding procedure.

Be careful not to damage the Teflon cone ring. The valve housing must be free from stresses (external loads) after installation.

Fig. 5

Never use QDV or any other Danfoss product to get an earth connection for welding as it might cause damage to the product.

Assembly:

Remove welding debris and any dirt from pipes and valve body before assembly. Check that the O-ring between the valve body and bonnet, as well as the Teflon cone ring in the valve seat is without marks or scratches.

Tightening:

Tighten the bonnet with a torque wrench, to the values indicated in the table (fig. 4).

Colors and identification:

The QDV 15 valves are painted with a red oxide primer in the factory.

Precise identification of the valve is made via the ID ring at the top of the bonnet, as well as by the stamping on the valve body.

The external surface of the valve housing must be prevented against corrosion with a suitable protective coating after installation and assembly.

Protection of the ID ring when repainting the valve is recommended.

Maintenance

Dismantling the valve (fig. 3):

Do not remove the bonnet while the valve is still under pressure. Always close the stop valve before the QDV. Then proceed with activation of the QDV valve to make sure that it is not under pressure.

- Check that the O-ring (pos. A) has not been damaged.
- Check that the spindle is free of scratches and impact marks.
- Check that the Teflon cone ring is without marks or scratches.

Replacement of the O-ring between the bonnet and the valve body (fig. 4):

The QDV 15 is delivered with an extra O-ring. Remove the damaged O-ring (pos. A) from the bonnet and carefully install the new O-ring.

Assembly:

Remove any dirt from the body before the valve is assembled.

Check that the O-ring between the valve body and bonnet, as well as the Teflon gasket in the valve seat is without marks or scratches.

Tightening:

Tighten the bonnet with a torque wrench, to the values indicated in the table (fig. 4).

Use only original Danfoss parts for replacement.

New parts must be made of certified materials applicable for the refrigerant used.

In cases of doubt, please contact Danfoss.

Danfoss accepts no responsibility for errors and omissions.

Danfoss Industrial Refrigeration reserves the right to make changes to products and specifications without prior notice.

A possible issue with our quick oil drain valves type QDV which may not fully close off during an oil draining process.

This may present itself when a drainage pipe is installed on the outlet of the valve which generates a back pressure to the valve such that the valve is unable to fully close. This will not present itself if there is no drainage pipe installed on the valve outlet. Max. back pressure 10 bar.

In applications where a QDV valve is installed in a system and is normally operating with an outlet pipe, please ensure that full safety precautions are taken when draining oil and make sure the inlet to the vessel is isolated during the oil draining process.

PORTUGUÊS

Refrigerantes:

Aplicável a todos os refrigerantes comuns não inflamáveis, incluindo R717 e gases/líquidos não corrosivos dependendo da compatibilidade com o material de vedação.

Não são recomendados hidrocarbonetos inflamáveis. A QDV é uma válvula dependente de contrapressão. A válvula é recomendada apenas para utilização em circuitos abertos. Para obter mais informações, entre em contato com a Danfoss.

Faixa de temperatura:

QDV 15: -50/+150 °C (-58/+302 °F)

Faixa de pressão:

As válvulas são projetadas para uma pressão máx. de funcionamento de 40 bar g (580 psi g).

Para prevenir a geração de pressão hidráulica entre a válvula de bloqueio e a QDV, um dispositivo integral de alívio é incluído, abrindo a válvula lentamente se a pressão exceder 16 bar (232 psig).

Instalação:

A válvula tem que ser instalada depois de uma válvula de bloqueio com o eixo em posição vertical para cima e com direção de fluxo a partir do braço lateral (fig. 1).



Caso seja montado um tubo ou uma mangueira na saída da QDV é necessário efetuar cálculos para evitar a acumulação de contrapressão ao aliviar. Bloquear a saída da QDV causará perigo (geração de pressão hidráulica). Deverá ser usada uma mangueira de saída do mesmo tamanho da conexão de saída da válvula QDV.

A manivela pode ser girada 360° para otimização da posição de funcionamento (fig. 2). A válvula deve ser operada apenas manualmente sem a utilização de ferramentas ou outros dispositivos. A válvula foi projetada para suportar uma elevada pressão interna. No entanto, o sistema da tubulação deve ser projetado para evitar retenções de líquido e reduzir o risco de pressão hidráulica provocada pela expansão térmica. Certifique-se de que a válvula está protegida de transientes de pressão como "golpe de líquido" no sistema.

Direção de fluxo recomendada:

A válvula tem que ser instalada com direção de fluxo a partir do braço lateral (fig. 2).

Soldagem:

A tampa deve ser retirada antes da soldagem (fig. 4) para evitar danos no O-ring entre o corpo da válvula e a tampa, bem como o

anel de teflon do cone no assento da válvula. Apenas materiais e métodos de soldagem, compatíveis com o material do corpo da válvula, devem ser soldados no corpo. A válvula deve ser limpa internamente para remover resíduos no final da soldagem e antes de ser montada novamente. Evite a acumulação de resíduos e sujeira nas roscas do corpo e na tampa. Pode ser excluído o processo de remoção da tampa, desde que:

A temperatura na área entre o corpo da válvula e a tampa durante a soldagem não exceda os +150 °C/+302 °F.

Essa temperatura depende do método de soldagem, bem como de um resfriamento do corpo da válvula durante a própria soldagem. (O resfriamento pode ser garantido, por exemplo, colocando-se um pano molhado em volta do corpo da válvula.) Certifique-se de que não entra sujeira, resíduos da soldagem, etc. na válvula durante o procedimento de soldagem.

Tenha cuidado para não danificar o anel de teflon do cone. O corpo da válvula deve estar livre de tensão (cargas externas) após a instalação.

Fig. 5

Nunca use a QDV ou qualquer outro produto Danfoss como aterramento para soldagem, dado que isso pode danificar o produto.

Montagem:

Retire os resíduos da soldagem e quaisquer sujeiras dos tubos e do corpo da válvula antes da montagem. Verifique se o O-ring entre o corpo da válvula e a tampa, bem como o anel de teflon do cone no assento da válvula não apresentam marcas ou riscos.

Aperto:

Aperte a tampa com um torquímetro para os valores indicados na tabela (fig. 4).

Cores e identificação:

As válvulas QDV 15 são pintadas na fábrica com um primer de óxido vermelho.

A identificação precisa da válvula é feita através do anel de ID na parte superior da tampa, assim como através da estampagem no corpo da válvula. A superfície externa do corpo da válvula deve ser protegida contra corrosão com um revestimento protetor adequado após a instalação e montagem.

É recomendável a proteção do anel de ID ao pintar a válvula novamente.

Maintenance

Dismantling the valve (fig. 3):

Do not remove the bonnet while the valve is still under pressure. Always close the stop valve before the QDV. Then proceed with activation of the QDV valve to make sure that it is not under pressure.

- Check that the O-ring (pos. A) has not been damaged.
- Check that the spindle is free of scratches and impact marks.
- Check that the Teflon cone ring is without marks or scratches.

Replacement of the O-ring between the bonnet and the valve body (fig. 4):

The QDV 15 is delivered with an extra O-ring. Remove the damaged O-ring (pos. A) from the bonnet and carefully install the new O-ring.

Assembly:

Remove any dirt from the body before the valve is assembled.

Check that the O-ring between the valve body and bonnet, as well as the Teflon gasket in the valve seat is without marks or scratches.

Tightening:

Tighten the bonnet with a torque wrench, to the values indicated in the table (fig. 4).

Use only original Danfoss parts for replacement.

New parts must be made of certified materials applicable for the refrigerant used.

In cases of doubt, please contact Danfoss.

Danfoss accepts no responsibility for errors and omissions.

Danfoss Industrial Refrigeration reserves the right to make changes to products and specifications without prior notice.

A possible issue with our quick oil drain valves type QDV which may not fully close off during an oil draining process.

This may present itself when a drainage pipe is installed on the outlet of the valve which generates a back pressure to the valve such that the valve is unable to fully close. This will not present itself if there is no drainage pipe installed on the valve outlet. Max. back pressure 10 bar.

In applications where a QDV valve is installed in a system and is normally operating with an outlet pipe, please ensure that full safety precautions are taken when draining oil and make sure the inlet to the vessel is isolated during the oil draining process.

