

Data sheet

Solenoid valves

EVRA and EVRAT



EVRA is a direct or servo operated solenoid valve for liquid, suction and hot gas lines with ammonia or fluorinated refrigerants.

EVRA valves are supplied complete or as separate components, i.e. valve body, coil and flanges can be ordered separately.

EVRAT is an assisted lift, servo operated solenoid valve for liquid, suction and hot gas lines with ammonia and fluorinated refrigerants.

EVRAT is specially designed to open - and stay open - at a pressure drop of 0 bar. The EVRAT solenoid valve is thus suitable for use in all plant where the required opening differential pressure is 0 bar.

EVRAT is available as components, i.e. valve body, flanges and coil must be ordered separately.

EVRAT 10, 15 and 20 all have spindle for manual operation.

Technical data

- Refrigerants:
Applicable to HCFC, HFC and R717 (Ammonia).
- Temperature of medium
-40°C – +105°C.
Max. 130°C during defrosting.
- Ambient temperature and enclosure for coil See "Coils for solenoid valves", AI237186440089
- Classification: DNV, CRN, BV, EAC etc.
To get an updated list of certification on the products please contact your local Danfoss Sales Company.

Type	Opening differential pressure with standard coil (Δp bar)				Temperature of medium °C	Max. working pressure PB bar	k_v -value ¹⁾ m ³ /h
	Max. (= MOPD) liquid ²⁾						
	Min.	10 W a.c.	12 W a.c.	20 W d.c.			
EVRA 3	0.00	21	25	14	-40 → 105	42	0.23
EVRA 10	0.05	21	25	18	-40 → 105	42	1.5
EVRAT 10	0.00	14	21	16	-40 → 105	42	1.5
EVRA 15	0.05	21	25	18	-40 → 105	42	2.7
EVRAT 15	0.00	14	21	16	-40 → 105	42	2.7
EVRA 20 with a.c. coil	0.05	21	25	13	-40 → 105	42	4.5
EVRA 20 with d.c. coil	0.05	19	21	16	-40 → 105	42	4.5
EVRAT 20	0.00	14	21	13	-40 → 105	42	4.5
EVRA 25	0.20	21	25	14	-40 → 105	42	10.0
EVRA 32	0.20	21	25	14	-40 → 105	42	16.0
EVRA 40	0.20	21	25	14	-40 → 105	42	25.0

¹⁾ The k_v value is the water flow in m³/h at a pressure drop across valve of 1 bar, $\rho = 1000 \text{ kg/m}^3$.

²⁾ MOPD for media in gas form is approx. 1 bar greater.

Contents	Page
Technical data.....	1
Ordering	3
Rated capacity	4
Liquid capacity	4
Suction vapour capacity	5
Hotgas capacity	7
Design/ Function.....	13
Material specification.....	14
Dimensions and weight.....	15

Ordering valve with coil

Type	Manual Stem	Inlet connection type	Orifice size [mm]	Max OPD 10W AC [bar]	Max OPD 20W DC [bar]	Coil type	Coil connection	Supply voltage [V] AC	Frequency [Hz]	Power consumption [W]	Singlepack/ Multipack (12 pcs.)	Code number
EVRA 3	No	Flange*	3	21	14	BF230AS	Cable (1 m/3.3 ft)	220 - 230	50	10	Multipack	032F310231
EVRA 3	No	Flange*	3	21	14	BE230AS	Connection Box	220 - 230	50	10	Multipack	032F310331
EVRA 3	No	Flange*	3	21	14	BE230CS	Connection Box	220 - 230	50/60	10	Multipack	032F310332
EVRA 10	No	Flange*	10	21	18	BE230AS	Connection Box	220 - 230	50	10	Multipack	032F620831
EVRA 10	Yes	Flange*	10	21	18	BF230AS	Cable (1 m/3.3 ft)	220 - 230	50	10	Singlepack	032F621231
EVRA 10	Yes	Flange*	10	21	18	BE230AS	Connection Box	220 - 230	50	10	Singlepack	032F621331
EVRA 10	Yes	Flange*	10	21	18	BE230CS	Connection Box	220 - 230	50/60	10	Singlepack	032F621332
EVRA 15	No	Flange*	15	21	18	BF230AS	Cable (1 m/3.3 ft)	220 - 230	50	10	Singlepack	032F621731
EVRA 15	No	Flange*	15	21	18	BF230CS	Cable (1 m/3.3 ft)	220 - 230	50/60	10	Singlepack	032F621732
EVRA 15	No	Flange*	15	21	18	BE230AS	Connection Box	220 - 230	50	10	Singlepack	032F621831
EVRA 15	No	Flange*	15	21	18	BE230CS	Connection Box	220 - 230	50/60	10	Singlepack	032F621832
EVRA 20	No	Flange*	20	21	13	BF230AS	Cable (1 m/3.3 ft)	220 - 230	50	10	Singlepack	032F622231
EVRA 20	No	Flange*	20	21	13	BE230AS	Connection Box	220 - 230	50	10	Singlepack	032F622331
EVRA 20	No	Flange*	20	21	13	BE230CS	Connection Box	220 - 230	50/60	10	Singlepack	032F622332
EVRA 25	Yes	Flange*	25	21	14	BE230CS	Connection Box	220 - 230	50/60	10	Singlepack	032F803432

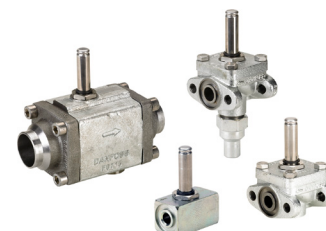
Ordering valve without coil

Type	Manual Stem	Inlet connection type	Inlet size [in]	Orifice size [mm]	Max OPD 10W AC [bar]	Max OPD 12W AC [bar]	Max OPD 20W DC [bar]	Required coil type**	Singlepack/ Multipack (12 pcs.)	Code number
EVRA 3	No	Flange*		3	21	25	14	AC / DC	Multipack	032F3050
EVRA 10	Yes	Flange*		10	21	25	18	AC / DC	Singlepack	032F6210
EVRA 10	No	Flange*		10	21	25	18	AC / DC	Singlepack	032F6211
EVRAT 10	Yes	Flange*		10	14	21	16	AC / DC	Singlepack	032F6214
EVRA 15	Yes	Flange*		15	21	25	18	AC / DC	Singlepack	032F6215
EVRAT 15	Yes	Flange*		15	14	21	16	AC / DC	Singlepack	032F6216
EVRAT 20	Yes	Flange*		20	14	21	13	AC / DC	Singlepack	032F6219
EVRA 20	Yes	Flange*		20	21	25	13	AC	Singlepack	032F6220
EVRA 20	Yes	Flange*		20	19	21	16	AC / DC	Singlepack	032F6221
EVRA 25	Yes	Flange*		25	21	25	14	AC / DC	Singlepack	032F6225
EVRA 25	No	Flange*		25	21	25	14	AC / DC	Singlepack	032F6226
EVRA 32	Yes	Butt weld DIN	1¼	22.2	21	25	14	AC / DC	Singlepack	042H1126
EVRA 32	No	Butt weld DIN	1¼	22.2	21	25	14	AC / DC	Singlepack	042H1127
EVRA 40	Yes	Butt weld DIN	1½	25.4	21	25	14	AC / DC	Singlepack	042H1128
EVRA 40	No	Butt weld DIN	1½	25.4	21	25	14	AC / DC	Singlepack	042H1129
EVRA 32	Yes	Butt weld DIN	1½	22.2	21	25	14	AC / DC	Singlepack	042H1131
EVRA 40	Yes	Butt weld DIN	2	25.4	21	25	14	AC / DC	Singlepack	042H1132
EVRA 32	Yes	Butt weld ANSI 36.10	1¼	22.2	21	25	14	AC / DC	Singlepack	042H1140
EVRA 32	Yes	Butt weld ANSI 36.10	1½	22.2	21	25	14	AC / DC	Singlepack	042H1141
EVRA 40	Yes	Butt weld ANSI 36.10	1½	25.4	21	25	14	AC / DC	Singlepack	042H1142
EVRA 40	Yes	Butt weld ANSI 36.10	2	25.4	21	25	14	AC / DC	Singlepack	042H1143

* Includes flange gaskets and bolts. For ordering flanges; please download the data sheet AI249786497379 from www.danfoss.com

** For ordering coils; please download the data sheet AI237186440089 from www.danfoss.com

Rated capacity

Type	Rated capacity ¹⁾ [kW]											
	Liquid				Suction vapour				Hot gas			
	R717	R22	R134a	R404A	R717	R22	R134a	R404A	R717	R22	R134a	R404A
EVRA 3	21.8	4.6	4.3	3.2				6.5	2.1	1.7	1.7	
EVRA/T 10	142.0	30.2	27.8	21.1	9.0	3.4	2.5	3.1	42.6	13.9	11.0	11.3
EVRA/T 15	256.0	54.4	50.1	38.0	16.1	6.2	4.4	5.5	76.7	24.9	19.8	20.3
EVRA/T 20	426.0	90.6	83.5	63.3	26.9	10.3	7.3	9.2	128.0	41.5	32.9	33.9
EVRA 25	947.0	201.0	186.0	141.0	59.7	22.8	16.3	20.4	284.0	92.3	73.2	75.3
EVRA 32	1515.0	322.0	297.0	225.0	95.5	36.5	26.1	32.6	454.0	148.0	117.0	120.0
EVRA 40	2368.0	503.0	464.0	351.0	149.0	57.0	40.8	51.0	710.0	231.0	183.0	188.0

¹⁾ Rated liquid and suction vapour capacity is based on evaporating temperature $t_e = -10^\circ\text{C}$, liquid temperature ahead of valve $t_l = +25^\circ\text{C}$, and pressure drop across valve $\Delta p = 0.15$ bar.

Rated hot gas capacity is based on condensing temperature $t_c = +40^\circ\text{C}$, pressure drop across valve $\Delta p = 0.8$ bar, hot gas temperature $t_h = +65^\circ\text{C}$, and subcooling of refrigerant $\Delta t_{\text{sub}} = 4$ K.

Capacity
Liquid capacity Q_l kW

Type	Liquid capacity Q_e kW at pressure drop across valve Δp bar				
	0.1	0.2	0.3	0.4	0.5

R 717 (NH₃)

EVRA 3	17.8	25.1	30.8	35.6	39.8
EVRA/T 10	116.0	164.0	201.0	232.0	259.0
EVRA/T 15	209.0	295.0	362.0	418.0	467.0
EVRA/T 20	348.0	492.0	603.0	696.0	778.0
EVRA 25	773.0	1093.0	1340.0	1547.0	1729.0
EVRA 32	1237.0	1749.0	2144.0	2475.0	2766.0
EVRA 40	1933.0	2734.0	3349.0	3867.0	4322.0

R 22

EVRA 3	3.8	5.3	6.6	7.6	8.5
EVRA/T 10	24.7	34.9	42.7	49.3	55.1
EVRA/T 15	44.4	62.8	76.9	88.8	99.2
EVRA/T 20	73.9	105.0	128.0	148.0	165.0
EVRA 25	165.0	232.0	285.0	329.0	368.0
EVRA 32	263.0	372.0	455.0	526.0	588.0
EVRA 40	411.0	581.0	712.0	822.0	919.0

R 134a

EVRA 3	3.5	4.9	6.0	7.0	7.8
EVRA/T 10	22.7	32.2	39.4	45.5	50.8
EVRA/T 15	40.9	57.9	70.9	81.8	91.5
EVRA/T 20	68.2	96.5	118.0	136.0	153.0
EVRA 25	152.0	214.0	263.0	303.0	339.0
EVRA 32	243.0	343.0	420.0	485.0	542.0
EVRA 40	379.0	536.0	656.0	758.0	847.0

R 404A

EVRA 3	2.6	3.7	4.6	5.3	5.9
EVRA/T 10	17.2	24.3	29.8	34.4	38.5
EVRA/T 15	31.0	43.8	53.7	62.0	69.3
EVRA/T 20	51.7	73.0	89.5	103.0	116.0
EVRA 25	115.0	162.0	199.0	230.0	257.0
EVRA 32	184.0	260.0	318.0	367.0	411.0
EVRA 40	287.0	406.0	497.0	574.0	642.0

Capacities are based on liquid temperature $t_l = +25^\circ\text{C}$ ahead of valve, evaporating temperature $t_e = -10^\circ\text{C}$, and superheat 0 K.

Correction factors

When sizing valves, the plant capacity must be multiplied by a correction factor depending on liquid temperature t_l ahead of valve/evaporator.

When the corrected capacity is known, the selection can be made from the table.

t_l °C	-10	0	+10	+20	+25	+30	+40	+50
R 717 (NH ₃)	0.84	0.88	0.92	0.97	1.0	1.03	1.09	1.16
R 22, R 134a	0.76	0.81	0.88	0.96	1.0	1.05	1.16	1.31
R 404A	0.70	0.76	0.84	0.94	1.0	1.07	1.24	1.47

Data sheet | Solenoid valves type EVRA and EVRAT
Capacity
(continued)

Suction vapour capacity Q_e kW

Type	Pressure drop across valve Δp bar	Suction vapour capacity Q_e kW at evaporating temperature t_e °C					
		-40	-30	-20	-10	0	+10

R 717 (NH₃)

EVRA/T 10	0.1	3.4	4.5	5.9	7.3	8.9	10.6
	0.15	4.0	5.4	7.0	9.0	10.9	13.0
	0.2	4.5	6.1	7.9	10.0	12.6	15.0
EVRA/T 15	0.1	6.1	8.1	10.7	13.2	16.0	19.1
	0.15	7.2	9.7	12.5	16.1	19.6	23.4
	0.2	8.0	11.0	14.2	18.0	22.6	27.0
EVRA/T 20	0.1	10.2	13.5	17.8	21.9	26.6	31.9
	0.15	12.1	16.1	20.9	26.9	32.6	39.0
	0.2	13.4	18.3	23.7	29.9	37.7	45.1
EVRA 25	0.1	22.6	30.0	39.5	48.7	59.2	70.8
	0.15	26.7	35.9	46.3	59.7	72.5	86.7
	0.2	29.8	40.5	52.7	66.4	83.7	100.0
EVRA 32	0.1	36.2	47.8	63.2	77.9	94.7	113.0
	0.15	42.7	57.4	74.1	95.5	116.0	139.0
	0.2	47.7	64.8	84.3	106.0	134.0	160.0
EVRA 40	0.1	56.5	74.8	98.8	122.0	148.0	177.0
	0.15	66.8	89.8	116.0	149.0	181.0	217.0
	0.2	74.5	101.0	132.0	166.0	209.0	251.0

R 22

EVRA/T 10	0.1	1.4	1.8	2.3	2.8	3.4	4.0
	0.15	1.6	2.1	2.7	3.4	4.1	4.9
	0.2	1.8	2.4	3.1	3.8	4.8	5.6
EVRA/T 15	0.1	2.5	3.2	4.1	5.0	6.1	7.2
	0.15	2.9	3.8	4.8	6.2	7.4	8.8
	0.2	3.3	4.3	5.5	6.8	8.6	10.2
EVRA/T 20	0.1	4.1	5.3	6.8	8.4	10.1	12.0
	0.15	4.9	6.4	8.1	10.3	12.3	14.7
	0.2	5.5	7.2	9.2	11.4	14.3	16.9
EVRA 25	0.1	9.1	11.8	15.2	18.6	22.4	26.6
	0.15	10.9	14.2	17.9	22.8	27.4	32.6
	0.2	12.2	16.1	20.4	25.3	31.7	37.6
EVRA 32	0.1	14.6	18.9	24.3	29.8	35.8	42.6
	0.15	17.4	22.7	28.8	36.5	43.8	52.2
	0.2	19.6	25.7	32.6	40.5	50.7	60.2
EVRA 40	0.1	22.8	29.5	38.1	46.5	56.0	66.5
	0.15	27.2	35.4	45.0	57.0	68.6	81.5
	0.2	30.5	40.2	51.0	63.3	79.2	94.0

Capacities are based on liquid temperature $t_l = +25^\circ\text{C}$ ahead of evaporator.
The table values refer to the evaporator capacity and are given as a function of evaporating temperature t_e and pressure drop Δp across valve.
Capacities are based on dry, saturated vapour ahead of valve.
During operation with superheated vapour ahead of valve, the capacities are reduced by 4% for each 10 K superheat.

Correction factors

When sizing valves, the evaporator capacity must be multiplied by a correction factor depending on liquid temperature t_l ahead of expansion valve.
When the corrected capacity is known, the selection can be made from the table.

t_l °C	-10	0	+10	+20	+25	+30	+40	+50
R 717 (NH ₃)	0.84	0.88	0.92	0.97	1.0	1.03	1.09	1.16
R 22	0.76	0.81	0.88	0.96	1.0	1.05	1.16	1.31

Data sheet | Solenoid valves type EVRA and EVRAT

Capacity (continued)

Suction vapour capacity Q_e kW

Type	Pressure drop across valve Δp bar	Suction vapour capacity Q_e kW at evaporating temperature t_e °C					
		-40	-30	-20	-10	0	+10

R 134a

EVRA/T 10	0.1	0.87	1.2	1.6	2.1	2.6	3.2
	0.15	0.99	1.4	1.9	2.4	3.2	3.9
	0.2	1.1	1.6	2.1	2.8	3.5	4.5
EVRA/T 15	0.1	1.6	2.1	2.8	3.8	4.7	5.7
	0.15	1.8	2.5	3.4	4.4	5.7	7.0
	0.2	2.0	2.8	3.8	5.0	6.3	8.1
EVRA/T 20	0.1	2.6	3.6	4.7	6.3	7.8	9.5
	0.15	3.0	4.2	5.6	7.3	9.5	11.7
	0.2	3.3	4.7	6.4	8.3	10.5	13.5
EVRA 25	0.1	5.8	7.9	10.5	13.9	17.2	21.1
	0.15	6.6	9.3	12.5	16.3	21.1	25.9
	0.2	7.3	10.4	14.1	18.5	23.4	29.9
EVRA 32	0.1	9.3	12.6	16.8	22.2	27.7	33.8
	0.15	10.6	14.9	20.0	26.1	33.8	41.4
	0.2	11.7	16.6	22.6	29.6	37.4	47.8
EVRA 40	0.1	14.5	19.8	26.3	34.8	43.3	52.8
	0.15	16.5	23.3	31.3	40.8	52.8	64.8
	0.2	18.3	26.0	35.3	46.3	58.5	74.8

R 404A

EVRA/T 10	0.1	1.2	1.5	2.0	2.5	3.1	3.7
	0.15	1.4	1.8	2.4	3.1	3.8	4.6
	0.2	1.6	2.1	2.7	3.4	4.3	5.3
EVRA/T 15	0.1	2.1	2.7	3.6	4.5	5.5	6.6
	0.15	2.5	3.3	4.3	5.5	6.8	8.2
	0.2	2.8	3.7	4.9	6.1	7.8	9.5
EVRA/T 20	0.1	3.5	4.6	6.0	7.5	9.2	11.1
	0.15	4.1	5.5	7.1	9.2	11.3	13.6
	0.2	4.6	6.2	8.1	10.2	13.0	15.8
EVRA 25	0.1	7.7	10.1	13.3	16.6	20.4	24.6
	0.15	9.1	12.1	15.8	20.4	25.0	30.3
	0.2	10.3	13.8	18.0	22.7	28.8	35.0
EVRA 32	0.1	12.3	16.2	21.3	26.6	32.6	39.4
	0.15	14.6	19.4	25.3	32.6	40.0	48.5
	0.2	16.5	22.0	28.8	36.3	46.1	56.0
EVRA 40	0.1	19.3	25.3	33.3	41.5	51.0	61.5
	0.15	22.9	30.3	39.5	51.0	62.5	75.6
	0.2	25.8	34.5	45.0	56.8	72.1	87.5

Capacities are based on liquid temperature $t_l = +25^\circ\text{C}$ ahead of evaporator.
The table values refer to the evaporator capacity and are given as a function of evaporating temperature t_e and pressure drop Δp across valve.
Capacities are based on dry, saturated vapour ahead of valve.
During operation with superheated vapour ahead of valve, the capacities are reduced by 4% for each 10 K superheat.

Correction factors

When sizing valves, the evaporator capacity must be multiplied by a correction factor depending on liquid temperature t_l ahead of expansion valve. When the corrected capacity is known, the selection can be made from the table.

t_l °C	-10	0	+10	+20	+25	+30	+40	+50
R 134a	0.76	0.81	0.88	0.96	1.0	1.05	1.16	1.31
R 404A	0.70	0.76	0.84	0.94	1.0	1.07	1.24	1.47

Capacity
(continued)

R 717 (NH₃)
Hot gas capacity Q_h kW

Type	Pressure drop across valve Δp bar	Hot gas capacity Q _e kW				
		Evaporating temp. t _e = -10°C. Hot gas temp. t _h = t _c + 25°C. Subcooling $\Delta t_{sub}=4K$				
		Condensing temperature t _c °C				
		+20	+30	+40	+50	+60
EVRA 3	0.1	1.8	2.1	2.3	2.5	2.6
	0.2	2.6	2.9	3.2	3.5	3.7
	0.4	3.8	4.2	4.6	4.9	5.3
	0.8	5.1	6.0	6.5	7.1	7.6
	1.6	7.4	8.3	9.1	9.9	10.9
EVRA/T 10	0.1	12.0	13.4	14.7	16.0	17.2
	0.2	17.1	19.0	20.9	22.7	24.4
	0.4	24.5	27.1	29.7	32.2	34.7
	0.8	34.0	39.0	42.6	46.1	49.5
	1.6	48.5	53.8	59.1	64.3	71.3
EVRA/T 15	0.1	21.7	24.1	26.4	28.8	31.0
	0.2	30.8	34.2	37.5	40.8	44.0
	0.4	44.1	48.8	53.5	58.0	62.4
	0.8	61.2	70.3	76.7	83.0	89.1
	1.6	87.4	96.9	106.0	116.0	128.0
EVRA/T 20	0.1	36.1	40.1	44.0	48.0	51.7
	0.2	51.4	57.0	62.6	68.0	73.2
	0.4	73.5	81.3	89.1	96.7	104.0
	0.8	102.0	117.0	128.0	138.0	148.0
	1.6	146.0	161.0	177.0	193.0	214.0
EVRA 25	0.1	80.2	89.1	98.0	107.0	115.0
	0.2	114.0	127.0	139.0	151.0	163.0
	0.4	163.0	181.0	198.0	215.0	231.0
	0.8	227.0	260.0	284.0	307.0	330.0
	1.6	324.0	358.0	394.0	429.0	475.0
EVRA 32	0.1	128.0	143.0	157.0	171.0	184.0
	0.2	183.0	203.0	223.0	242.0	260.0
	0.4	261.0	289.0	317.0	344.0	370.0
	0.8	362.0	416.0	455.0	492.0	528.0
	1.6	518.0	574.0	631.0	688.0	761.0
EVRA 40	0.1	201.0	223.0	244.0	267.0	287.0
	0.2	286.0	317.0	348.0	378.0	407.0
	0.4	408.0	452.0	495.0	537.0	578.0
	0.8	566.0	650.0	710.0	769.0	825.0
	1.6	809.0	897.0	986.0	1074.0	1188.0

An increase in hot gas temperature t_h of 10 K, based on t_h = t_c + 25°C, reduces valve capacity approx. 2% and vice versa.

A change in evaporating temperature t_e changes valve capacity; see correction factor table below.

Correction factor

When sizing valves, the table value must be multiplied by a correction factor depending on evaporating temperature t_e.

t _e °C	-40	-30	-20	-10	0	+10
R 717 (NH ₃)	0.89	0.91	0.96	1.0	1.06	1.10

Capacity
(continued)

Hot gas capacity Q_h kW
R 22

Type	Pressure drop across valve Δp bar	Hot gas capacity Q_e kW				
		Evaporating temp. $t_e = -10^\circ\text{C}$. Hot gas temp. $t_h = t_c + 25^\circ\text{C}$. Subcooling $\Delta t_{\text{sub}} = 4\text{K}$				
		Condensing temperature t_c $^\circ\text{C}$				
		+20	+30	+40	+50	+60
EVRA 3	0.1	0.68	0.72	0.76	0.78	0.79
	0.2	0.97	1.0	1.1	1.1	1.1
	0.4	1.4	1.5	1.5	1.6	1.6
	0.8	1.9	2.0	2.1	2.3	2.3
	1.6	2.7	2.9	3.0	3.1	3.2
EVRA/T 10	0.1	4.4	4.7	4.9	5.1	5.2
	0.2	6.3	6.7	7.0	7.2	7.3
	0.4	9.0	9.6	10.0	10.3	10.4
	0.8	12.4	13.2	13.9	14.7	14.9
	1.6	17.5	18.6	19.6	20.2	20.5
EVRA/T 15	0.1	8.0	8.5	8.9	9.2	9.3
	0.2	11.4	12.1	12.6	13.0	13.2
	0.4	16.3	17.2	18.0	18.5	18.7
	0.8	22.3	23.1	24.9	26.5	26.8
	1.6	31.5	33.5	35.2	36.4	36.9
EVRA/T 20	0.1	13.3	14.1	14.8	15.3	15.5
	0.2	19.0	20.1	21.0	21.7	22.0
	0.4	27.1	28.7	30.0	30.9	31.2
	0.8	37.1	38.4	41.5	44.2	44.6
	1.6	52.5	55.9	58.6	60.6	61.5
EVRA 25	0.1	29.6	31.4	32.9	34.0	34.4
	0.2	42.1	44.6	46.7	48.2	48.8
	0.4	60.2	63.8	66.6	68.6	69.4
	0.8	82.5	87.9	92.3	98.2	99.2
	1.6	117.0	124.0	130.0	135.0	137.0
EVRA 32	0.1	47.4	50.2	52.6	54.4	55.0
	0.2	67.4	71.4	74.7	77.1	78.1
	0.4	96.3	102.0	107.0	110.0	111.0
	0.8	132.0	140.0	148.0	157.0	159.0
	1.6	187.0	199.0	209.0	216.0	219.0
EVRA 40	0.1	74.0	78.5	82.3	85.0	86.0
	0.2	105.0	112.0	117.0	121.0	122.0
	0.4	151.0	159.0	167.0	172.0	174.0
	0.8	206.0	222.0	231.0	246.0	248.0
	1.6	291.0	310.0	326.0	337.0	342.0

An increase in hot gas temperature t_h of 10 K, based on $t_h = t_c + 25^\circ\text{C}$, reduces valve capacity approx. 2% and vice versa.

A change in evaporating temperature t_e changes valve capacity; see correction factor table below.

Correction factor

When sizing valves, the table value must be multiplied by a correction factor depending on evaporating temperature t_e .

t_e $^\circ\text{C}$	-40	-30	-20	-10	0	+10
R 22	0.90	0.94	0.97	1.0	1.03	1.05

Capacity
(continued)

R 134a
Hot gas capacity Q_h kW

Type	Pressure drop across valve Δp bar	Hot gas capacity Q_e kW				
		Evaporating temp. $t_e = -10^\circ\text{C}$. Hot gas temp. $t_h = t_c + 25^\circ\text{C}$. Subcooling $\Delta t_{\text{sub}} = 4\text{K}$				
		Condensing temperature t_c $^\circ\text{C}$				
		+20	+30	+40	+50	+60
EVRA 3	0.1	0.54	0.57	0.6	0.61	0.6
	0.2	0.77	0.82	0.85	0.86	0.85
	0.4	1.1	1.2	1.2	1.2	1.2
	0.8	1.5	1.6	1.7	1.8	1.8
	1.6	2.2	2.3	2.4	2.5	2.4
EVRA/T 10	0.1	3.5	3.7	3.9	4.0	3.9
	0.2	5.0	5.3	5.5	5.6	5.6
	0.4	7.0	7.7	7.9	8.0	7.9
	0.8	9.9	10.5	11.0	11.6	11.4
	1.6	14.3	15.1	15.7	16.0	15.9
EVRA/T 15	0.1	6.4	6.7	7.0	7.1	7.1
	0.2	9.1	9.6	10.0	10.1	10.0
	0.4	12.6	13.8	14.2	14.4	14.3
	0.8	17.9	19.0	19.8	20.8	20.5
	1.6	25.7	27.2	28.2	28.8	28.6
EVRA/T 20	0.1	10.6	11.2	11.7	11.8	11.8
	0.2	15.1	16.0	16.6	16.8	16.7
	0.4	21.0	22.9	23.7	24.0	23.8
	0.8	29.8	31.6	33.0	34.7	34.2
	1.6	42.8	45.3	47.1	47.9	47.6
EVRA 25	0.1	23.6	24.9	25.9	26.4	26.2
	0.2	33.6	35.5	36.8	37.4	37.1
	0.4	46.6	51.0	52.7	53.4	52.9
	0.8	66.2	70.2	73.2	77.0	76.0
	1.6	95.2	101.0	105.0	107.0	106.0
EVRA 32	0.1	37.6	39.8	41.4	42.1	41.8
	0.2	53.8	56.8	58.9	59.8	59.4
	0.4	74.7	81.6	84.3	85.4	84.6
	0.8	106.0	112.0	117.0	123.0	122.0
	1.6	152.0	161.0	167.0	170.0	169.0
EVRA 40	0.1	58.8	62.3	64.7	65.8	65.3
	0.2	84.1	88.8	92.1	93.5	92.8
	0.4	117.0	127.0	132.0	134.0	132.0
	0.8	166.0	176.0	183.0	192.0	190.0
	1.6	238.0	252.0	262.0	266.0	265.0

An increase in hot gas temperature t_h of 10 K, based on $t_h = t_c + 25^\circ\text{C}$, reduces valve capacity approx. 2% and vice versa.

A change in evaporating temperature t_e changes valve capacity; see correction factor table below.

Correction factor

When sizing valves, the table value must be multiplied by a correction factor depending on evaporating temperature t_e .

t_e $^\circ\text{C}$	-40	-30	-20	-10	0	+10
R 134a	0.88	0.92	0.98	1.0	1.04	1.08

Capacity
(continued)

Hot gas capacity Q_h kW
R 404A

Type	Pressure drop across valve Δp bar	Hot gas capacity Q_e kW				
		Evaporating temp. $t_e = -10^\circ\text{C}$. Hot gas temp. $t_h = t_c + 25^\circ\text{C}$. Subcooling $\Delta t_{\text{sub}} = 4\text{K}$				
		Condensing temperature t_c °C				
		+20	+30	+40	+50	+60
EVRA 3	0.1	0.62	0.63	0.62	0.59	0.54
	0.2	0.87	0.89	0.88	0.83	0.76
	0.4	1.2	1.3	1.3	1.2	1.1
	0.8	1.7	1.7	1.7	1.7	1.5
	1.6	2.4	2.5	2.4	2.3	2.1
EVRA/T 10	0.1	4.0	4.1	4.0	3.8	3.5
	0.2	5.7	5.8	5.7	5.5	5.0
	0.4	8.1	8.2	8.2	7.8	7.0
	0.8	11.1	11.4	11.3	11.1	10.1
	1.6	15.7	16.0	15.8	15.2	13.9
EVRA/T 15	0.1	7.3	7.4	7.3	6.9	6.3
	0.2	10.2	10.4	10.3	9.8	8.9
	0.4	14.6	14.8	14.7	14.0	12.7
	0.8	20.1	20.4	20.3	20.0	18.1
	1.6	28.3	28.8	28.4	27.4	25.0
EVRA/T 20	0.1	12.1	12.3	12.1	11.5	10.5
	0.2	17.1	17.3	17.2	16.3	14.9
	0.4	24.4	24.7	24.5	23.3	21.1
	0.8	33.4	34.0	33.9	33.3	30.2
	1.6	47.1	48.0	47.4	45.6	41.6
EVRA 25	0.1	26.8	27.4	26.9	25.6	23.3
	0.2	37.9	38.4	38.2	36.3	33.0
	0.4	54.2	54.9	54.5	51.7	47.0
	0.8	74.2	75.6	75.3	74.0	67.2
	1.6	105.0	107.0	105.0	101.0	92.5
EVRA 32	0.1	43.0	43.8	43.0	40.9	37.3
	0.2	60.6	61.4	61.1	58.1	52.8
	0.4	86.7	87.8	87.2	82.7	75.2
	0.8	119.0	121.0	120.0	118.0	107.0
	1.6	167.0	171.0	168.0	162.0	148.0
EVRA 40	0.1	67.0	68.5	67.3	64.0	58.3
	0.2	94.8	96.0	95.5	90.8	82.5
	0.4	136.0	137.0	136.0	129.0	117.0
	0.8	186.0	189.0	188.0	185.0	168.0
	1.6	262.0	266.0	263.0	253.0	231.0

An increase in hot gas temperature t_h of 10 K, based on $t_h = t_c + 25^\circ\text{C}$, reduces valve capacity approx. 2% and vice versa.

A change in evaporating temperature t_e changes valve capacity; see correction factor table below.

Correction factor

When sizing valves, the table value must be multiplied by a correction factor depending on evaporating temperature t_e .

t_e °C	-40	-30	-20	-10	0	+10
R 404A	0.86	0.88	0.93	1.0	1.03	1.07

Data sheet | Solenoid valves type EVRA and EVRAT

Capacity
(continued)

Hot gas capacity G_h kg/s

Type	Hot gas temperature t_h °C	Condensing temperature t_k °C	Hot gas capacity G_h kg/s at pressure drop across valve Δp bar								
			0.5	1	2	3	4	5	6	7	8

R 717 (NH₃)

EVRA 3	+90	+25	0.003	0.005	0.006	0.007	0.007	0.007	0.007	0.007	0.007
		+35	0.004	0.005	0.007	0.009	0.009	0.01	0.01	0.01	0.01
		+45	0.005	0.006	0.009	0.01	0.011	0.012	0.013	0.013	0.013
EVRA/T 10		+25	0.022	0.03	0.04	0.045	0.048	0.048	0.048	0.048	0.048
		+35	0.026	0.036	0.048	0.056	0.061	0.064	0.065	0.065	0.065
		+45	0.030	0.041	0.056	0.066	0.074	0.079	0.083	0.085	0.086
EVRA/T 15		+25	0.040	0.054	0.072	0.081	0.086	0.087	0.087	0.087	0.087
		+35	0.046	0.064	0.086	0.1	0.109	0.115	0.117	0.117	0.117
		+45	0.053	0.074	0.101	0.12	0.133	0.142	0.149	0.153	0.155
EVRA/T 20		+25	0.066	0.09	0.12	0.12	0.144	0.145	0.145	0.145	0.145
		+35	0.077	0.107	0.144	0.167	0.182	0.191	0.195	0.195	0.195
		+45	0.089	0.124	0.169	0.199	0.211	0.237	0.248	0.255	0.258
EVRA 25	+25	0.143	0.197	0.26	0.296	0.313	0.316	0.316	0.316	0.316	
	+35	0.168	0.232	0.313	0.364	0.397	0.417	0.425	0.425	0.425	
	+45	0.194	0.269	0.368	0.434	0.482	0.516	1.54	0.555	0.561	
EVRA 32	+25	0.233	0.322	0.424	0.483	0.511	0.516				
	+35	0.274	0.379	0.511	0.594	0.648	0.681	0.694			
	+45	0.316	0.439	0.601	0.709	0.787	0.842	0.882	0.906	0.916	
EVRA 40	+25	0.362	0.503	0.663	0.755	0.798	0.806				
	+35	0.429	0.592	0.798	0.929	1.013	1.064	1.084			
	+45	0.495	0.686	0.939	1.107	1.23	1.316	1.378	1.416	1.431	

R 22

EVRA 3	+90	+25	0.008	0.011	0.014	0.016	0.017	0.017	0.017	0.017	0.017
		+35	0.009	0.012	0.017	0.019	0.021	0.022	0.022	0.022	0.022
		+45	0.010	0.014	0.019	0.022	0.025	0.026	0.027	0.028	0.028
EVRA/T 10		+25	0.051	0.069	0.092	0.104	0.109	0.111	0.111	0.111	0.111
		+35	0.058	0.08	0.108	0.125	0.136	0.142	0.144	0.144	0.144
		+45	0.066	0.092	0.125	0.146	0.162	0.172	0.179	0.183	0.183
EVRA/T 15		+25	0.091	0.125	0.165	0.187	0.197	0.199	0.199	0.199	0.199
		+35	0.105	0.144	0.194	0.225	0.244	0.256	0.258	0.258	0.258
		+45	0.119	0.165	0.224	0.263	0.291	0.31	0.322	0.329	0.330
EVRA/T 20		+25	0.152	0.208	0.275	0.311	0.328	0.332	0.332	0.332	0.332
		+35	0.174	0.241	0.323	0.375	0.407	0.425	0.431	0.431	0.431
		+45	0.193	0.275	0.374	0.439	0.485	0.516	0.537	0.548	0.55
EVRA 25	+25	0.331	0.453	0.599	0.677	0.715	0.722	0.722	0.722	0.722	
	+35	0.38	0.524	0.704	0.816	0.886	0.925	0.938	0.938	0.938	
	+45	0.431	0.598	0.814	0.956	1.056	1.125	1.169	1.192	1.197	
EVRA 32	+25	0.539	0.739	0.976	1.106	1.168	1.179				
	+35	0.619	0.856	1.15	1.331	1.446	1.509	1.531			
	+45	0.704	0.978	1.329	1.562	1.723	1.837	1.909	1.947	1.955	
EVRA 40	+25	0.843	1.155	1.525	1.728	1.825	1.843				
	+35	0.968	1.338	1.798	2.08	2.26	2.358	2.393			
	+45	1.1	1.528	2.078	2.44	2.693	2.87	2.383	3.043	3.055	

An increase in hot gas temperature t_h of 10 K reduces valve capacity approx. 2% and vice versa.

Data sheet | Solenoid valves type EVRA and EVRAT
Capacity
(continued)

Hot gas capacity G_h kg/s

Type	Varmgas-temperatur t_h °C	Kondenseringstemp. t_k °C	Varmgaskapacitet G_h kg/s ved trykfaldet i ventilen Δp bar								
			0.5	1	2	3	4	5	6	7	8

R 134a

EVRA 3	+60	+25	0.007	0.009	0.011	0.012	0.012					
		+35	0.009	0.011	0.014	0.016	0.016	0.016	0.016			
		+45	0.01	0.012	0.018	0.02	0.021	0.021	0.021	0.021	0.021	0.021
EVRA/T 10		+25	0.048	0.06	0.074	0.077	0.077					
		+35	0.055	0.071	0.092	0.103	0.104	0.104				
		+45	0.06	0.084	0.111	0.127	0.134	0.135	0.135	0.135	0.135	0.135
EVRA/T 15		+25	0.081	0.108	0.134	0.14	0.14					
		+35	0.094	0.129	0.166	0.192	0.187	0.187	0.187			
		+45	0.108	0.151	0.2	0.228	0.241	0.244	0.244	0.244	0.244	0.244
EVRA/T 20		+25	0.134	0.18	0.223	0.233	0.233					
		+35	0.157	0.215	0.276	0.307	0.312	0.312	0.312			
		+45	0.181	0.252	0.333	0.381	0.403	0.407	0.407	0.407	0.407	0.407
EVRA 25	+25	0.292	0.391	0.486	0.506	0.506						
	+35	0.341	0.467	0.602	0.668	0.679	0.679	0.679				
	+45	0.393	0.549	0.725	0.83	0.876	0.885	0.885	0.885	0.885	0.885	
EVRA 32	+25	0.478	0.638	0.793	1.826	0.826						
	+35	0.556	0.763	0.994	1.091	1.108	1.108	1.108				
	+45	0.641	0.897	1.197	1.354	1.432	1.446	1.446	1.446	1.446	1.446	
EVRA 40	+25	0.747	0.998	1.24	1.291	1.291						
	+35	0.87	1.192	1.553	1.704	1.731	1.731	1.731				
	+45	1.002	1.402	1.87	2.117	2.237	2.259	2.259	2.259			

R 404A

EVRA 3	+60	+25	0.01	0.013	0.018	0.021	0.022	0.023	0.023	0.023	0.023
		+35	0.011	0.015	0.02	0.024	0.027	0.028	0.029	0.029	0.03
		+45	0.012	0.017	0.023	0.028	0.032	0.034	0.035	0.036	0.037
EVRA/T 10		+25	0.063	0.087	0.116	0.134	0.145	0.148	0.149	0.149	0.149
		+35	0.072	0.1	0.134	0.158	0.174	0.184	0.19	0.19	0.192
		+45	0.081	0.112	0.153	0.182	0.203	0.228	0.228	0.237	0.239
EVRA/T 15		+25	0.113	0.157	0.21	0.242	0.26	0.267	0.269	0.269	0.269
		+35	0.129	0.18	0.242	0.285	0.313	0.332	0.341	0.342	0.346
		+45	0.146	0.202	0.275	0.327	0.365	0.393	0.411	0.424	0.431
EVRA/T 20		+25	0.189	0.262	0.35	0.403	0.433	0.445	0.449	0.449	0.449
		+35	0.215	0.3	0.404	0.474	0.521	0.552	0.569	0.57	0.576
		+45	0.243	0.337	0.459	0.545	0.609	0.656	0.684	0.707	0.719
EVRA 25	+25	0.411	0.57	0.763	0.878	0.942	0.969	0.978	0.978	0.978	
	+35	0.468	0.653	0.881	1.032	1.136	1.203	1.239	1.241	1.253	
	+45	0.529	0.734	1.0	1.188	1.326	1.43	1.49	1.539	1.566	
EVRA 32	+25	0.672	0.931	1.245	1.432	1.539	1.581	1.581	1.581	1.581	
	+35	0.765	1.069	1.436	1.686	1.854	1.964	2.022	2.025	2.025	
	+45	0.862	1.198	1.632	1.939	1.836	2.34	2.433	2.513	2.557	
EVRA 40	+25	1.05	1.454	1.946	2.238	2.406	2.471	2.471	2.471	2.471	
	+35	1.195	1.657	2.245	2.635	2.897	3.068	3.161	3.166	3.166	
	+45	1.348	1.873	2.55	3.03	3.384	3.65	3.801	3.926	3.995	

An increase in hot gas temperature t_h of 10 K reduces valve capacity approx. 2% and vice versa.

**Design
Function**

- 4. Coil
- 16. Armature
- 18. Valve plate / Pilot valve plate
- 20. Earth terminal
- 24. Connection for flexible steel hose
- 28. Gasket
- 29. Pilot orifice
- 30. O-ring
- 31. Piston ring
- 36. DIN plug
- 40. Terminal box
- 43. Valve cover
- 44. O-ring
- 45. Valve cover gasket
- 48. Flange gasket
- 49. Valve body
- 51. Cover / Threaded plug
- 53. Manual operation spindle
- 59. Strainer
- 73. Equalization hole
- 74. Main channel
- 75. Pilot channel
- 76. Compression spring
- 80. Diaphragm/Servo piston
- 82. Support washer
- 83. Valve seat
- 84. Main valve plate

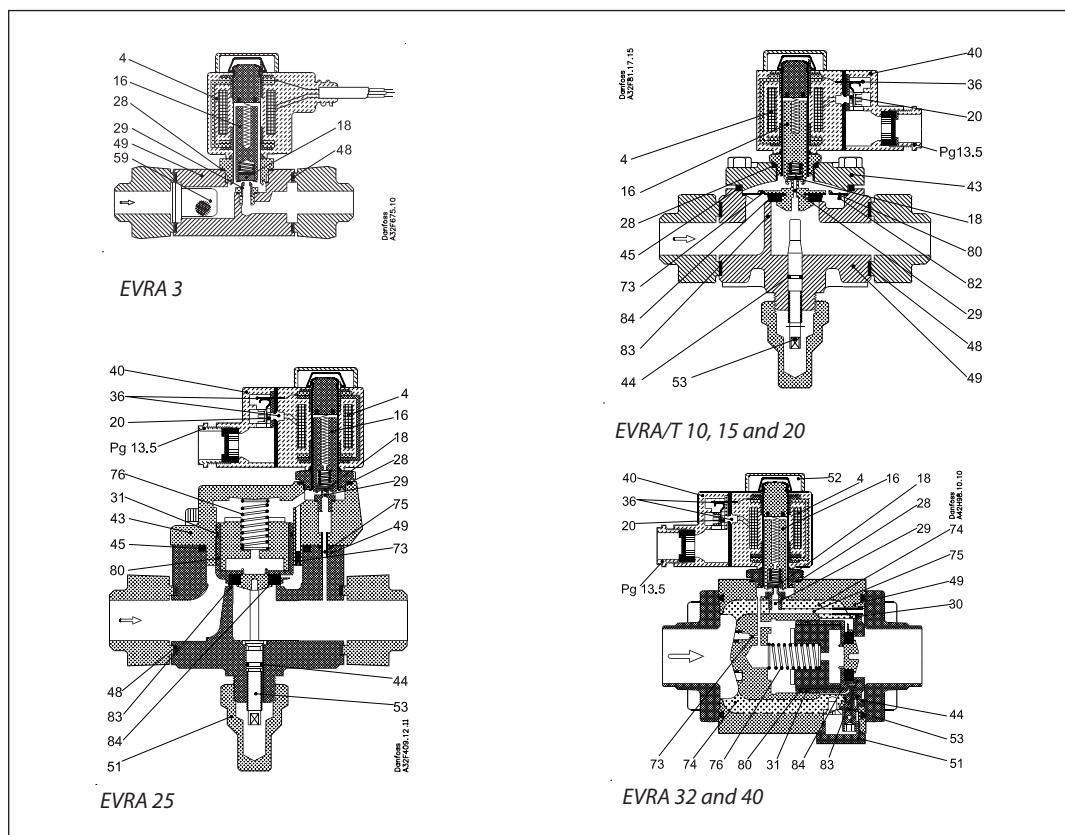

EVRA solenoid valves are designed on two different principles:

1. Direct operation
2. Servo operation

1. Direct operation

EVRA 3 is direct operated. The valve opens direct for full flow when the armature (16) moves up into the magnetic field of the coil. This means that the valve operates with a min. differential pressure of 0 bar. The teflon valve plate (18) is fitted direct on the armature (16).

Inlet pressure acts from above on the armature and the valve plate. Thus, inlet pressure, spring force and the weight of the armature act to close the valve when the coil is currentless.

2. Servo operation

EVRA/T 10 → 20 are servo operated with a “floating” diaphragm (80). The pilot orifice (29) of stainless steel is placed in the centre of the diaphragm. The teflon pilot valve plate (18) is fitted direct to the armature (16). When the coil is currentless, the main orifice and pilot orifice are closed. The pilot orifice and main orifice are held closed by the weight of the armature, the armature spring force and the differential pressure between inlet and outlet sides.

When current is applied to the coil the armature is drawn up into the magnetic field and opens the pilot orifice. This relieves the pressure above the diaphragm, i.e. the space above the diaphragm becomes connected to the outlet side of the valve.

The differential pressure between inlet and outlet sides then presses the diaphragm away from the main orifice and opens it for full flow. Therefore a certain minimum

differential pressure is necessary to open the EVRA valve and keep it open. For differential pressure 0 bar use EVRAT valves.

For EVRA 10 → 20 valves this differential pressure is 0.05 bar.

When current is switched off, the pilot orifice closes. Via the equalization holes (73) in the diaphragm, the pressure above the diaphragm then rises to the same value as the inlet pressure and the diaphragm closes the main orifice.

EVRA 25, 32 and 40 are servo operated piston valves. The valves are closed with currentless coil.

The servo piston (80) with main valve plate (84) closes against the valve seat (83) by means of the differential pressure between inlet and outlet side of the valve, the force of the compression spring (76) and possibly the piston weight.

When current to the coil is switched on, the pilot orifice (29) opens. This relieves the pressure on the piston spring side of the valve. The differential pressure will then open the valve.

The minimum differential pressure needed for full opening of the valves is 0.2 bar.



The manual opener of EVRA/EVRAT 10, 15, 20 and 25 is intended to be activated only during initial pressure testing of the refrigeration system.

After pressure testing or service-related manual forced opening of the manual opener the spindle **must** be turned fully back to back-seated position to avoid any packing gland leakage.

Furthermore it is essential that the sealing cap is properly reinstalled. This will eliminate any risk of leakage from the manual opener.

Data sheet | Solenoid valves type EVRA and EVRAT

Material specification

EVRA 3

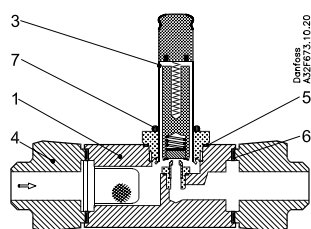

EVRA/T
10/15/20

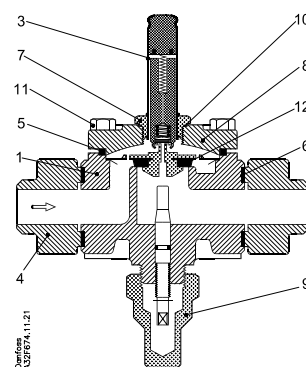

No.	Description	Solenoid valves	Material	Analysis	Mat.no.	W.no.	ISO	EN
1	Valve body	EVRA 3	Free-cutting steel	11MnPb30				10277-3
	Valve body	EVRA/T 10/15/20	Cast-iron	GJS-400-18-LT				1563
3	Armature tube	EVRA 3/10/15/20	Stainless steel	X2CrNi19-11				10088
4	Flange	EVRA/T 3/10/15/20	Steel	S235JRG2				10025
5	Gasket	EVRA 3	Aluminium	Al 99.5				10210
	Gasket	EVRA/T 10/15/20	Rubber	Cr				
6	Gasket	EVRA/T 3/10/15/20	asbestos-free					
7	Armature tube nut	EVRA/T 3/10/15/20	Stainless steel	X8CrNiS18-9				10088
8	Cover	EVRA/T 10/15/20	Cast-iron	GJS-400-18-LT				1563
9	Cover/ thread plug	EVRA/T 10/15/20	Free-cutting steel	11SMnPb30				10277-3
10	Gasket	EVRA/T 10/15/20	Aluminium	Al 99.5				10210
11	Bolts	EVRA/T 10/15/20	Stainless steel	A2-70			3506	
12	Valve seat	EVRA/T 10/15/20	Teflon (PTFE)					

EVRA 25

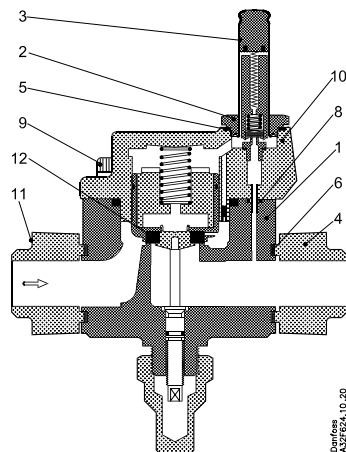

EVRA 32/40

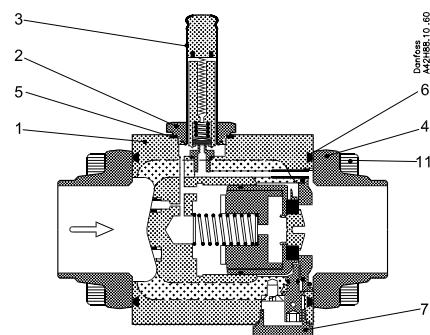

No.	Description	Solenoid valves	Material	Analysis	Mat.no.	W.no.	ISO	EN
1	Valve body	EVRA 25/32/40	Cast-iron	GJS-400-18-LT				1563
2	Armature tube nut	EVRA 25/32/40	Stainless steel	X8CrNiS 18-9				10088
3	Armature tube	EVRA 25/32/40	Stainless steel	X2CrNi19-11				10088
4	Flange	EVRA 25	Steel	S235JRG2				10025
	Flange	EVRA 32/40	Steel	P285QH				10222-4
5	Gasket	EVRA 25/32/40	Stainless steel/NBR	X10CrNi18-8				1.4310
6	Gasket	EVRA 25	asbestos-free					
	Gasket	EVRA 32/40	Rubber	Cr				
7	Cover/thread plug	EVRA 25	Free-cutting steel	11SMnPb30				10277-3
	Cover/thread plug	EVRA 32/40	Stainless steel	X5CrNi17-10				10088
8	Gasket	EVRA 25	Rubber	CR				
9	Bolts	EVRA 25	Stainless steel	A2-70			3506	
10	Cover	EVRA 25	Cast-iron	GJS-400-18-LT				1563
11	Bolts	EVRA 25/32/40	Stainless steel	A2-70			3506	
12	Valve seat	EVRA 25	Teflon (PTFE)					

Dimensions and weight

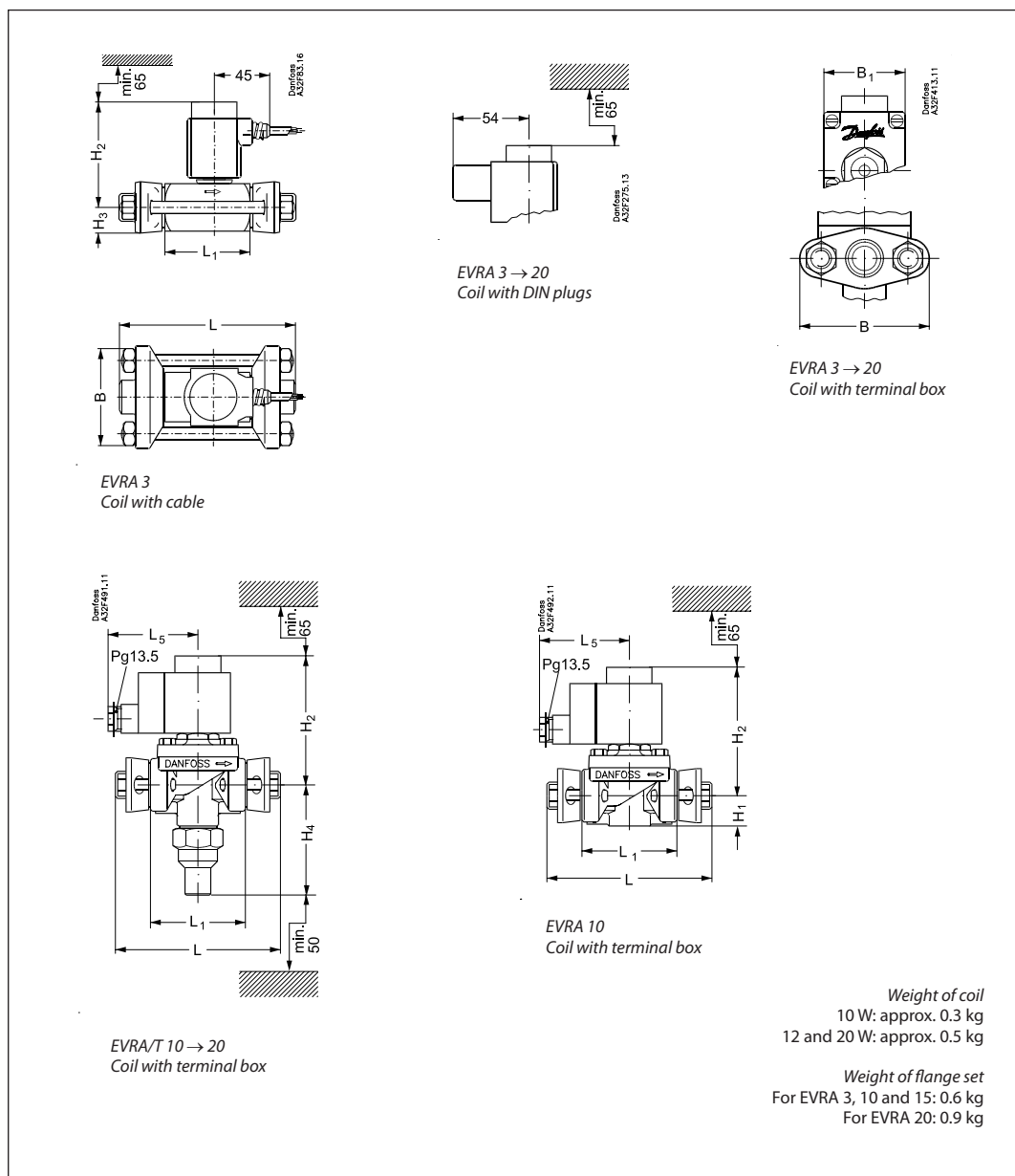

Type	H ₁	H ₂	H ₃	H ₄	L	L ₁	L ₅ max.		B	B ₁ max.	Weight ¹⁾
							10 W	12 W 20 W			
							mm	mm			
EVRA 3		84	19		124	65	75	85	80	68	1.2
EVRA/T 10	22	100		81	130	68			80	68	1.7
EVRA/T 15		100		81	130	68			80	68	1.8
EVRA/T 20		110		77	155	85			96	68	2.7

¹⁾ With coil, without flanges

Dimensions and weight
(continued)

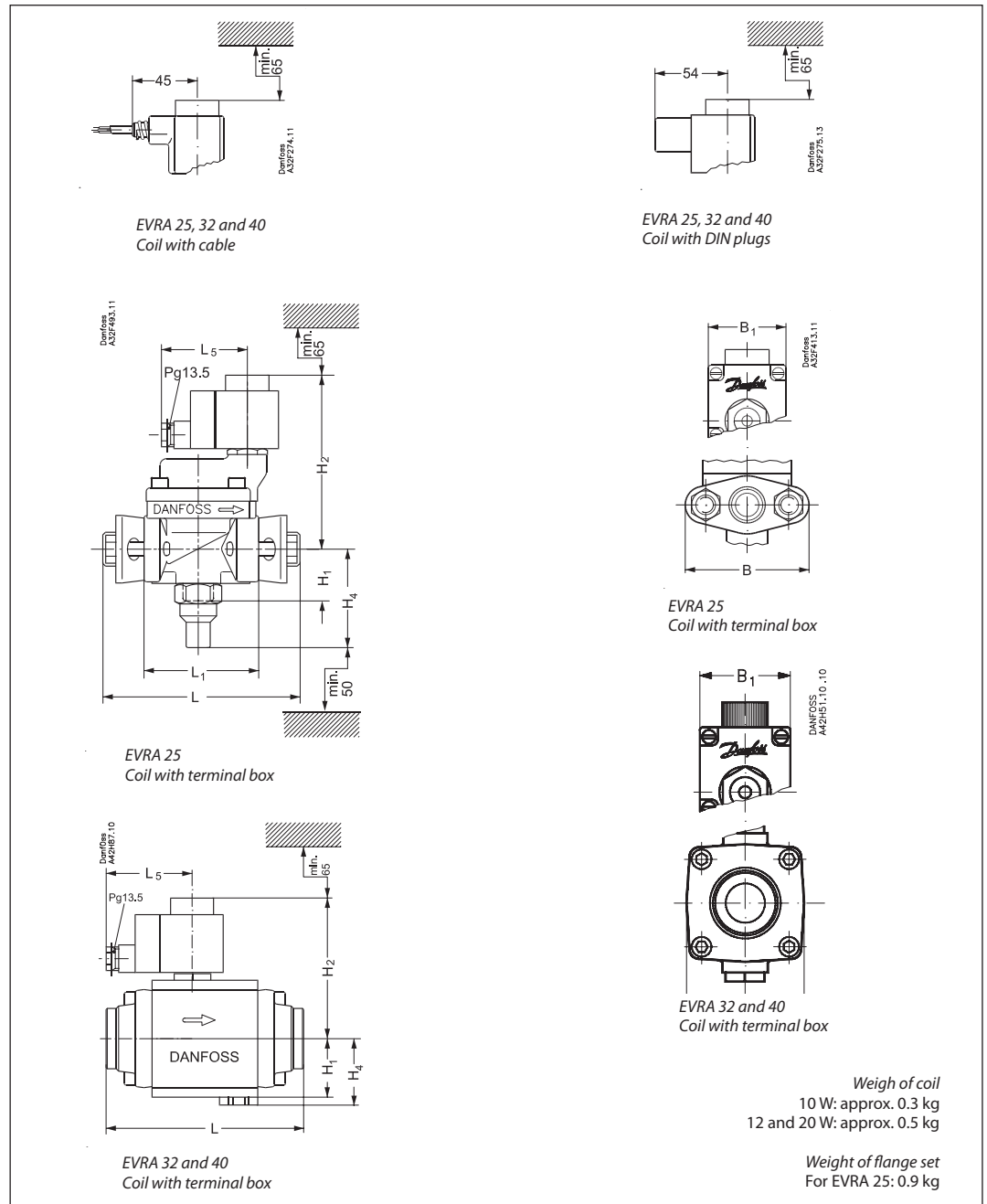

Type	H ₁	H ₂	H ₃	H ₄	L	L ₁	L ₃ max.		B	B ₁ max.	Weight ¹⁾
							10 W	12 W 20 W			
							mm	mm			
EVRA 25	46	141		78	162	92	75	85	95	68	3.0
EVRA 32	47	115		53	175	80			68	4.0	
EVRA 40	47	115		53	175	80			68	4.0	

¹⁾ With coil, without flanges